



1

MAIN SPECIFICATIONS

AISI 316 stainless steel precision casting

- Matte finish ($R_a < 0.8 \mu\text{m}$) **MT**
- Polished finish ($R_a < 0.8 \mu\text{m}$) **PL**



2

Sealing ring

- H-NBR **H**

Temperature resistant $-25\text{ }^\circ\text{C}$ to $+150\text{ }^\circ\text{C}$

- EPDM **E**

Temperature resistant $-40\text{ }^\circ\text{C}$ to $+120\text{ }^\circ\text{C}$

- FKM **F**

Temperature resistant $-5\text{ }^\circ\text{C}$ to $+200\text{ }^\circ\text{C}$

- Blue

- Hardness 85 ± 5 Shore A

- FDA compliant



3



4



5



6

FEATURES AND APPLICATIONS

Wing screws GN 8351 comply with the DGUV testing principles and are intended for use in hygienic areas. The version with PL finish is additionally certified according to the guidelines of the EHEDG.

The sealed mounting surface enables mounting without dead spaces; the impervious geometry in combination with the high quality finish prevents the accumulation of dirt and facilitates cleaning.

Wing nuts clamp and fasten parts easily without tools. The ergonomic shape allows for high tightening forces.

The wing nuts can also be used in particularly aggressive environments thanks to the material used.



7



8



9



10



11



12



13



14



15



16



17



18



19



20



NV 23193

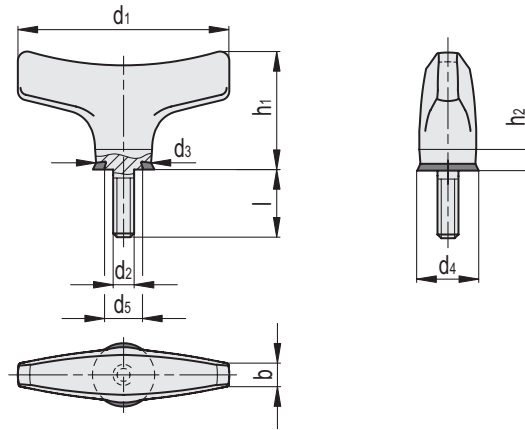

GN 8351-MT-H

INOX STAINLESS STEEL

Code	Description	d1	d2	d4	d3	d5	b	h1	h2	l	⚖
GN.50452	GN 8351-40-M4-8-MT-H	40	M 4	11.8	11	7	4	22	4	8	30
GN.50456	GN 8351-40-M4-12-MT-H	40	M 4	11.8	11	7	4	22	4	12	31
GN.50460	GN 8351-40-M4-16-MT-H	40	M 4	11.8	11	7	4	22	4	16	32
GN.50471	GN 8351-50-M5-12-MT-H	50	M 5	13.8	13	9	5	28	5	12	57
GN.50475	GN 8351-50-M5-16-MT-H	50	M 5	13.8	13	9	5	28	5	16	58
GN.50479	GN 8351-50-M5-20-MT-H	50	M 5	13.8	13	9	5	28	5	20	59
GN.50487	GN 8351-63-M6-16-MT-H	63	M 6	16.8	16	12	7	35	6	16	106
GN.50491	GN 8351-63-M6-20-MT-H	63	M 6	16.8	16	12	7	35	6	20	107
GN.50495	GN 8351-63-M6-25-MT-H	63	M 6	16.8	16	12	7	35	6	25	108

GN 8351-MT-E

Code	Description	d1	d2	d4	d3	d5	b	h1	h2	l	⚖
GN.50451	GN 8351-40-M4-8-MT-E	40	M 4	11.8	11	7	4	22	4	8	30
GN.50455	GN 8351-40-M4-12-MT-E	40	M 4	11.8	11	7	4	22	4	12	31
GN.50459	GN 8351-40-M4-16-MT-E	40	M 4	11.8	11	7	4	22	4	16	32
GN.50470	GN 8351-50-M5-12-MT-E	50	M 5	13.8	13	9	5	28	5	12	57
GN.50474	GN 8351-50-M5-16-MT-E	50	M 5	13.8	13	9	5	28	5	16	58
GN.50478	GN 8351-50-M5-20-MT-E	50	M 5	13.8	13	9	5	28	5	20	59
GN.50486	GN 8351-63-M6-16-MT-E	63	M 6	16.8	16	12	7	35	6	16	106
GN.50490	GN 8351-63-M6-20-MT-E	63	M 6	16.8	16	12	7	35	6	20	107
GN.50494	GN 8351-63-M6-25-MT-E	63	M 6	16.8	16	12	7	35	6	25	108

GN 8351-MT-F

Code	Description	d1	d2	d4	d3	d5	b	h1	h2	l	⚖
GN.50445	GN 8351-40-M4-8-MT-F	40	M 4	11.8	11	7	4	22	4	8	30
GN.50447	GN 8351-40-M4-12-MT-F	40	M 4	11.8	11	7	4	22	4	12	31
GN.50449	GN 8351-40-M4-16-MT-F	40	M 4	11.8	11	7	4	22	4	16	32
GN.50464	GN 8351-50-M5-12-MT-F	50	M 5	13.8	13	9	5	28	5	12	57
GN.50466	GN 8351-50-M5-16-MT-F	50	M 5	13.8	13	9	5	28	5	16	58
GN.50468	GN 8351-50-M5-20-MT-F	50	M 5	13.8	13	9	5	28	5	20	59
GN.50482	GN 8351-63-M6-16-MT-F	63	M 6	16.8	16	12	7	35	6	16	106
GN.50484	GN 8351-63-M6-20-MT-F	63	M 6	16.8	16	12	7	35	6	20	107
GN.50498	GN 8351-63-M6-25-MT-F	63	M 6	16.8	16	12	7	35	6	25	108

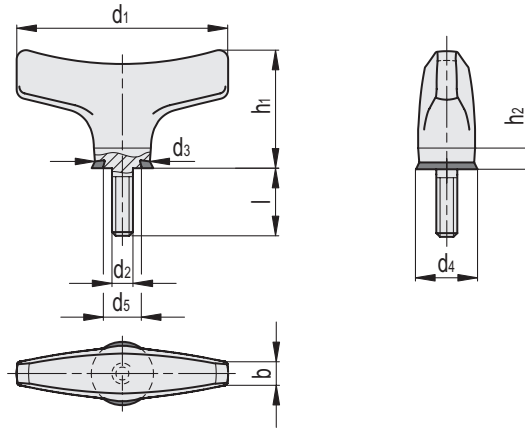
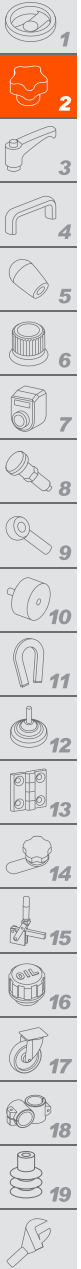

INOX STAINLESS STEEL

GN 8351-PL-H

Code	Description	d1	d2	d4	d3	d5	b	h1	h2	l	△
GN.50458	GN 8351-40-M4-12-PL-H	40	M 4	11.8	11	7	4	22	4	12	31
GN.50462	GN 8351-40-M4-16-PL-H	40	M 4	11.8	11	7	4	22	4	16	32
GN.50454	GN 8351-40-M4-8-PL-H	40	M 4	11.8	11	7	4	22	4	8	30
GN.50473	GN 8351-50-M5-12-PL-H	50	M 5	13.8	13	9	5	28	5	12	57
GN.50477	GN 8351-50-M5-16-PL-H	50	M 5	13.8	13	9	5	28	5	16	58
GN.50481	GN 8351-50-M5-20-PL-H	50	M 5	13.8	13	9	5	28	5	20	59
GN.50489	GN 8351-63-M6-16-PL-H	63	M 6	16.8	16	12	7	35	6	16	106
GN.50493	GN 8351-63-M6-20-PL-H	63	M 6	16.8	16	12	7	35	6	20	107
GN.50497	GN 8351-63-M6-25-PL-H	63	M 6	16.8	16	12	7	35	6	25	108

GN 8351-PL-E

Code	Description	d1	d2	d4	d3	d5	b	h1	h2	l	△
GN.50457	GN 8351-40-M4-12-PL-E	40	M 4	11.8	11	7	4	22	4	12	31
GN.50461	GN 8351-40-M4-16-PL-E	40	M 4	11.8	11	7	4	22	4	16	32
GN.50453	GN 8351-40-M4-8-PL-E	40	M 4	11.8	11	7	4	22	4	8	30
GN.50472	GN 8351-50-M5-12-PL-E	50	M 5	13.8	13	9	5	28	5	12	57
GN.50476	GN 8351-50-M5-16-PL-E	50	M 5	13.8	13	9	5	28	5	16	58
GN.50480	GN 8351-50-M5-20-PL-E	50	M 5	13.8	13	9	5	28	5	20	59
GN.50488	GN 8351-63-M6-16-PL-E	63	M 6	16.8	16	12	7	35	6	16	106
GN.50492	GN 8351-63-M6-20-PL-E	63	M 6	16.8	16	12	7	35	6	20	107
GN.50496	GN 8351-63-M6-25-PL-E	63	M 6	16.8	16	12	7	35	6	25	108

GN 8351-PL-F

Code	Description	d1	d2	d4	d3	d5	b	h1	h2	l	△
GN.50446	GN 8351-40-M4-8-PL-F	40	M 4	11.8	11	7	4	22	4	8	30
GN.50448	GN 8351-40-M4-12-PL-F	40	M 4	11.8	11	7	4	22	4	12	31
GN.50450	GN 8351-40-M4-16-PL-F	40	M 4	11.8	11	7	4	22	4	16	32
GN.50465	GN 8351-50-M5-12-PL-F	50	M 5	13.8	13	9	5	28	5	12	57
GN.50467	GN 8351-50-M5-16-PL-F	50	M 5	13.8	13	9	5	28	5	16	58
GN.50469	GN 8351-50-M5-20-PL-F	50	M 5	13.8	13	9	5	28	5	20	59
GN.50483	GN 8351-63-M6-16-PL-F	63	M 6	16.8	16	12	7	35	6	16	106
GN.50485	GN 8351-63-M6-20-PL-F	63	M 6	16.8	16	12	7	35	6	20	107
GN.50499	GN 8351-63-M6-25-PL-F	63	M 6	16.8	16	12	7	35	6	25	108